



HEP-1000

User's Manual

0. Safety Guidelines	1
1. Introduction	1
1.1 Introduction	1
1.2 Features	1
1.3 Order Information	1
1.4 Main Specification	2
2. Mechanical Specification and Input/Output Terminals	4
2.1 Mechanism	4
3. Functions	5
3.1 Input Voltage Range	5
3.2 Inrush Current Limiting	5
3.3 Rated Power	5
3.4 Power Factor Correction (PFC)	5
3.5 Output Voltage/Current Adjustment	6
3.6 Short-Circuit and Over-Current Protection	7
3.7 Over-Voltage Protection	7
3.8 Over-Temperature Protection and Alarm	7
3.9 DC OK Signal	7
3.10 Remote Control	7
3.11 Auxiliary Power	7
3.12 Factory Resetting	7
4. Communication Protocol	8
4.1 Charging Curve	8
4.2 PMBus Addressing and CAN ID setting	8
4.3 PMBus Command List	9
4.4 CANBus Communication Interface	17
4.5 CANBus Command list	18
5. Notes on Operation	29
5.1 Installation Method	29
5.2 Derating	29
5.3 Warranty	29
5.4 Suggestion of Battery Capacity	30
5.5 Troubleshooting	30



HEP- 1000 User's Manual

0.Safety Guidelines

- ⊙Risk of electrical shock and hazard, all failure should be examined by a qualified technician. Please do not remove the case from the supply by yourself.
- ⊙Please do not change any component on the unit or make any kind of modification on it.
- ⊙The input voltage range is 100-240Vac(50/60Hz), please do not feed in voltage that is over or less than 10% of that range.

1.Introduction

1.1 Introduction

HEP-1000 is equipped with modes of industrial power supply and charger, which can be selected by the communication interface.

1.2 Feature Description

- ⊙Built-in active PFC function.
- ⊙High efficiency up 96%.
- ⊙Fanless design, cooling by free air convection.
- ⊙Aluminum case and filling with heat-conducted glue.
- ⊙Optional wiring type with IP67 rating.
- ⊙Withstand 10G vibration test.
- ⊙-40~70°C wide operating range .
- ⊙Charger for lead-acid batteries (flooded, Gel and AGM) and Li-ion batteries (lithium iron and lithium manganese).
- ⊙Built-in default 2/3 stage charging curves and programmable curve.
- ⊙Built-in PMBus protocol/ Optional CANBus protocol.
- ⊙Output voltage/current programming.
- ⊙Protections: Short-circuit/ Overload/ Over voltage/ Over temperature.
- ⊙Built-in remote ON-OFF control.
- ⊙DC OK signal.
- ⊙LED indicator.
- ⊙6 years warranty.

1.3 Order Information

1.3.1 Explanation for Encoding

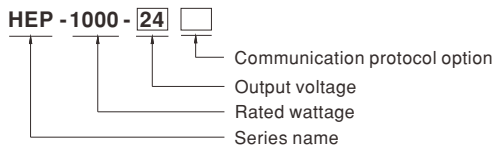

Type	Communication Protocol	Note
Blank	PMBus protocol	In Stock
CAN	CANBus protocol	By request

1.3.2 Marking

- ⊙Please refer to the safety label sticker on the top of the unit before use, shown as Figure 1-1.

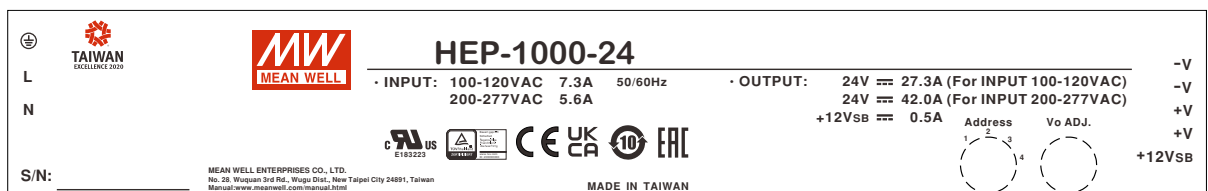

Figure 1-1 Safety label of UHP-1000

1.4 Main Specification

☉Power supply

MODEL	HEP-1000-24 □ □		HEP-1000-48 □ □		HEP-1000-100 □ □			
OUTPUT	DC VOLTAGE	24V		48V		100V		
	RATED CURRENT	42A		21A		10A		
	RATED POWER	1008W		1008W		1000W		
	RIPPLE & NOISE (max.) Note.2	200mVp-p		250mVp-p		500mVp-p		
	VOLTAGE ADJ. RANGE	By built-in potentiometer, SVR						
		24 ~ 30V		48 ~ 60V		100 ~ 125V		
	VOLTAGE TOLERANCE Note.3	±1.0%		±1.0%		±1.0%		
	LINE REGULATION	±0.5%		±0.5%		±0.5%		
	LOAD REGULATION	±0.5%		±0.5%		±0.5%		
	SETUP, RISE TIME	1800ms, 80ms at full load		230VAC /115VAC				
HOLD UP TIME (Typ.)	16ms / 230VAC at 75% load		12ms / 230VAC at full load					
INPUT	VOLTAGE RANGE Note.4	90 ~ 305VAC		250 ~ 431VDC				
	FREQUENCY RANGE	47 ~ 63Hz						
	POWER FACTOR (Typ.)	PF>0.99/115VAC, PF>0.95/230VAC, PF>0.93/277VAC at full load						
	EFFICIENCY (Typ.)	95%		96%		96%		
	AC CURRENT (Typ.)	10.1A / 115VAC		5.3A / 230VAC		4.5A / 277VAC		
	INRUSH CURRENT(Typ.)	Cold start 40A at 230VAC						
	LEAKAGE CURRENT	<0.75mA / 240VAC						
PROTECTION	OVERLOAD	105~125% rated current						
		Protection type : Constant current limiting, shut down O/P voltage after 5 sec. After O/P voltage falls, re-power on to recover						
	SHORT CIRCUIT	Constant current limiting, unit will shutdown after 5 sec, re-power on to recover						
	OVER VOLTAGE	30 ~ 35V		60 ~ 70V		125 ~ 145V		
		Protection type :Shut down O/P voltage,re-power on to recover						
OVER TEMPERATURE	Protection type :Shut down O/P voltage, recovers automatically after temperature goes down							
FUNCTION	OUTPUT VOLTAGE PROGRAMMABLE(PV) Note 5	Adjustment of output voltage is allowable to 50 ~ 125% of nominal output voltage Please refer to the Function Manual.						
	OUTPUT CURRENT PROGRAMMABLE(PC) Note 5	Adjustment of constant current level is allowable to 20 ~ 100% of rated current. Please refer to the Function Manual.						
	REMOTE ON/OFF CONTROL	Power ON : Short circuit Power OFF : Open circuit						
	AUXILIARY POWER	12V @ 0.5A tolerance ±10%, ripple=150mVp-p						
	DC-OK SIGNAL	The TTL signal out, PSU turn on = 4.4 ~ 5.5V ; PSU turn off = -0.5 ~ 0.5V. Please refer to the Function Manual.						
ENVIRONMENT	WORKING TEMP.	-40 ~ +70°C (Refer to "Derating Curve")						
	WORKING HUMIDITY	20 ~ 95% RH non-condensing						
	STORAGE TEMP., HUMIDITY	-40 ~ +80°C, 10 ~ 95% RH non-condensing						
	TEMP. COEFFICIENT	±0.03%/°C (0 ~ 50°C)						
	VIBRATION	20 ~ 500Hz, 10G 12min./1cycle, period for 72min. each along X, Y, Z axes						
SAFETY & EMC (Note.7)	SAFETY STANDARDS	UL62368-1,TUV BS EN/EN62368-1, EAC TP TC 004 approved; design refer to BS EN/EN61558-1, BS EN/EN60335-1(by request)						
	WITHSTAND VOLTAGE	I/P-O/P:3KVAC I/P-FG:2KVAC O/P-FG:1.25KVAC						
	ISOLATION RESISTANCE	I/P-O/P, I/P-FG,O/P-FG:100M Ohms/500VDC/25°C / 70%RH						
	EMC EMISSION	Parameter	Standard		Test Level / Note			
		Conducted	BS EN/EN55032 (CISPR32)		Class B			
		Radiated	BS EN/EN55032 (CISPR32)		Class B			
		Harmonic Current	BS EN/EN61000-3-2		Class A			
		Voltage Flicker	BS EN/EN61000-3-3		-----			
	EMC IMMUNITY	BS EN/EN55024 , BS EN/EN61000-6-2						
		Parameter	Standard		Test Level / Note			
		ESD	BS EN/EN61000-4-2		Level 3, 8KV air ; Level 2, 4KV contact			
		Radiated	BS EN/EN61000-4-3		Level 3			
		EFT / Burst	BS EN/EN61000-4-4		Level 3			
		Surge	BS EN/EN61000-6-2		2KV/Line-Line 4KV/Line-Earth			
		Conducted	BS EN/EN61000-4-6		Level 3			
Magnetic Field		BS EN/EN61000-4-8		Level 4				
Voltage Dips and Interruptions		BS EN/EN61000-4-11		>95% dip 0.5 periods, 30% dip 25 periods, >95% interruptions 250 periods				
OTHERS	MTBF	583.7K hrs min. Telcordia SR-332 (Bellcore) ; 52.3K hrs min. MIL-HDBK-217F (25°C)						
	DIMENSION	310*144*48.5mm (L*W*H)						
	PACKING	4Kg;4pcs/17Kg/1.04CUFT						
NOTE	<p>1. All parameters NOT specially mentioned are measured at 230VAC input, rated load and 25°C of ambient temperature.</p> <p>2. Ripple & noise are measured at 20MHz of bandwidth by using a 12" twisted pair-wire terminated with a 0.1uf & 47uf parallel capacitor.</p> <p>3. Tolerance :includes set up tolerance, line regulation and load regulation.</p> <p>4. Derating may be needed under low input voltages. Please check the derating curve for more details.</p> <p>5. PV/PC functions when users do not use SVR.</p> <p>6. In power mode: When O/P voltage is below < 80% of Vset for 5 sec. the unit will shut down afterwards.</p> <p>7. The power supply is considered a component which will be installed into a final equipment. All the EMC tests are been executed by mounting the unit on a 720mm*360mm metal plate with 1mm of thickness. The final equipment must be re-confirmed that it still meets EMC directives. For guidance on how to perform these EMC tests, please refer to "EMI testing of component power supplies." (as available on http://www.meanwell.com)</p> <p>8. The ambient temperature derating of 3.5°C/1000m with fanless models and of 5°C/1000m with fan models for operating altitude higher than 2000m(6500ft).</p> <p>※ Product Liability Disclaimer : For detailed information, please refer to https://www.meanwell.com/serviceDisclaimer.aspx</p>							

©Charger

MODEL		HEP-1000-24 <input type="checkbox"/> <input type="checkbox"/>	HEP-1000-48 <input type="checkbox"/> <input type="checkbox"/>	HEP-1000-100 <input type="checkbox"/> <input type="checkbox"/>	
OUTPUT	BOOST CHARGE VOLTAGE V_{boost}	28.8V	57.6V	115.2V	
	FLOAT CHARGE VOLTAGE V_{float}	27.6V	55.2V	110.4V	
	RECOMMENDED BATTERY CAPACITY(AMP HOURS)(Note 2)	120 ~ 350AH	60 ~ 175AH	30 ~ 85AH	
	BATTERY TYPE	Open & Sealed Lead Acid			
	OUTPUT CURRENT	35A	17.5A	8.7A	
INPUT	VOLTAGE RANGE <small>Note 3</small>	90 ~ 305VAC 250 ~ 431VDC			
	FREQUENCY RANGE	47 ~ 63Hz			
	POWER FACTOR (Typ.)	PF>0.99/115VAC, PF>0.95/230VAC, PF>0.93/277VAC at full load			
	EFFICIENCY (Typ.)	95%	96%	96%	
	AC CURRENT (Typ.)	10.1A / 115VAC	5.3A / 230VAC	4.5A / 277VAC	
	INRUSH CURRENT(Typ.)	Cold start 40A at 230VAC			
	LEAKAGE CURRENT	<0.75mA / 240VAC			
PROTECTION	SHORT CIRCUIT	Constant current limiting, unit will shutdown after 5 sec, re-power on to recover.			
	OVER VOLTAGE	30 ~ 35V	60 ~ 70V	125 ~ 145V	
	OVER TEMPERATURE	Protection type :Shutdown O/P voltage,re-power on to recover Protection type :Shutdown O/P voltage, recovers automatically after temperature goes down			
FUNCTION	REMOTE ON/OFF CONTROL	Power ON : Short circuit Power OFF : Open circuit			
	AUXILIARY POWER	12V @ 0.5A tolerance $\pm 10\%$, ripple=150mVp-p			
	DC-OK SIGNAL	The TTL signal out, PSU turn on = 4.4 ~ 5.5V ; PSU turn off = -0.5 ~ 0.5V. Please refer to the Function Manual.			
ENVIRONMENT	WORKING TEMP.	-40 ~ +70°C (Refer to "Derating Curve")			
	WORKING HUMIDITY	20 ~ 95% RH non-condensing			
	STORAGE TEMP., HUMIDITY	-40 ~ +80°C, 10 ~ 95% RH non-condensing			
	TEMP. COEFFICIENT	$\pm 0.03\%/^{\circ}\text{C}$ (0 ~ 50°C)			
	VIBRATION	20 ~ 500Hz, 10G 12min./1cycle, period for 72min. each along X, Y, Z axes			
SAFETY & EMC (Note.5)	SAFETY STANDARDS	UL62368-1,TUV BS EN/EN62368-1, EAC TP TC 004 approved; design refer to BS EN/EN61558-1, BS EN/EN60335-1(by request)			
	WITHSTAND VOLTAGE	I/P-O/P:3KVAC I/P-FG:2KVAC O/P-FG:1.25KVAC			
	ISOLATION RESISTANCE	I/P-O/P, I/P-FG,O/P-FG:100M Ohms/500VDC/25°C / 70%RH			
	EMC EMISSION	Parameter	Standard	Test Level / Note	
		Conducted	BS EN/EN55032 (CISPR32)	Class B	
		Radiated	BS EN/EN55032 (CISPR32)	Class A	
		Harmonic Current	BS EN/EN61000-3-2	Class A	
		Voltage Flicker	BS EN/EN61000-3-3	----	
	EMC IMMUNITY	BS EN/EN55024 , BS EN/EN61000-6-2			
		Parameter	Standard	Test Level / Note	
		ESD	BS EN/EN61000-4-2	Level 3, 8KV air ; Level 2, 4KV contact	
		Radiated	BS EN/EN61000-4-3	Level 3	
		EFT / Burst	BS EN/EN61000-4-4	Level 3	
		Surge	BS EN/EN61000-6-2	2KV/Line-Line 4KV/Line-Earth	
		Conducted	BS EN/EN61000-4-6	Level 3	
Magnetic Field		BS EN/EN61000-4-8	Level 4		
Voltage Dips and Interruptions		BS EN/EN61000-4-11	>95% dip 0.5 periods, 30% dip 25 periods, >95% interruptions 250 periods		
OTHERS	MTBF	583.7K hrs min. Telcordia SR-332 (Bellcore) ; 52.3K hrs min. MIL-HDBK-217F (25°C)			
	DIMENSION	310*144*48.5mm (L*W*H)			
	PACKING	4Kg;4pcs/17Kg/1.04CUFT			
NOTE	<p>1. All parameters NOT specially mentioned are measured at 230VAC input, rated load and 25°C of ambient temperature.</p> <p>2. This is Mean Well's suggested range. Please consult your battery manufacturer for their suggestions about maximum charging current limitation.</p> <p>3. Derating may be needed under low input voltages. Please check the derating curve for more details.</p> <p>4. In charge mode: When O/P voltage < 67% of Vset for 5 sec. the unit will shut down afterwards.</p> <p>5. The power supply is considered a component which will be installed into a final equipment. All the EMC tests are been executed by mounting the unit on a 720mm*360mm metal plate with 1mm of thickness. The final equipment must be re-confirmed that it still meets EMC directives. For guidance on how to perform these EMC tests, please refer to "EMI testing of component power supplies." (as available on http://www.meanwell.com)</p> <p>6. The ambient temperature derating of 3.5°C/1000m with fanless models and of 5°C/1000m with fan models for operating altitude higher than 2000m(6500ft).</p> <p>※ Product Liability Disclaimer : For detailed information, please refer to https://www.meanwell.com/serviceDisclaimer.aspx</p>				

2. Mechanical Specification and Input/Output Terminals

2.1 Mechanism

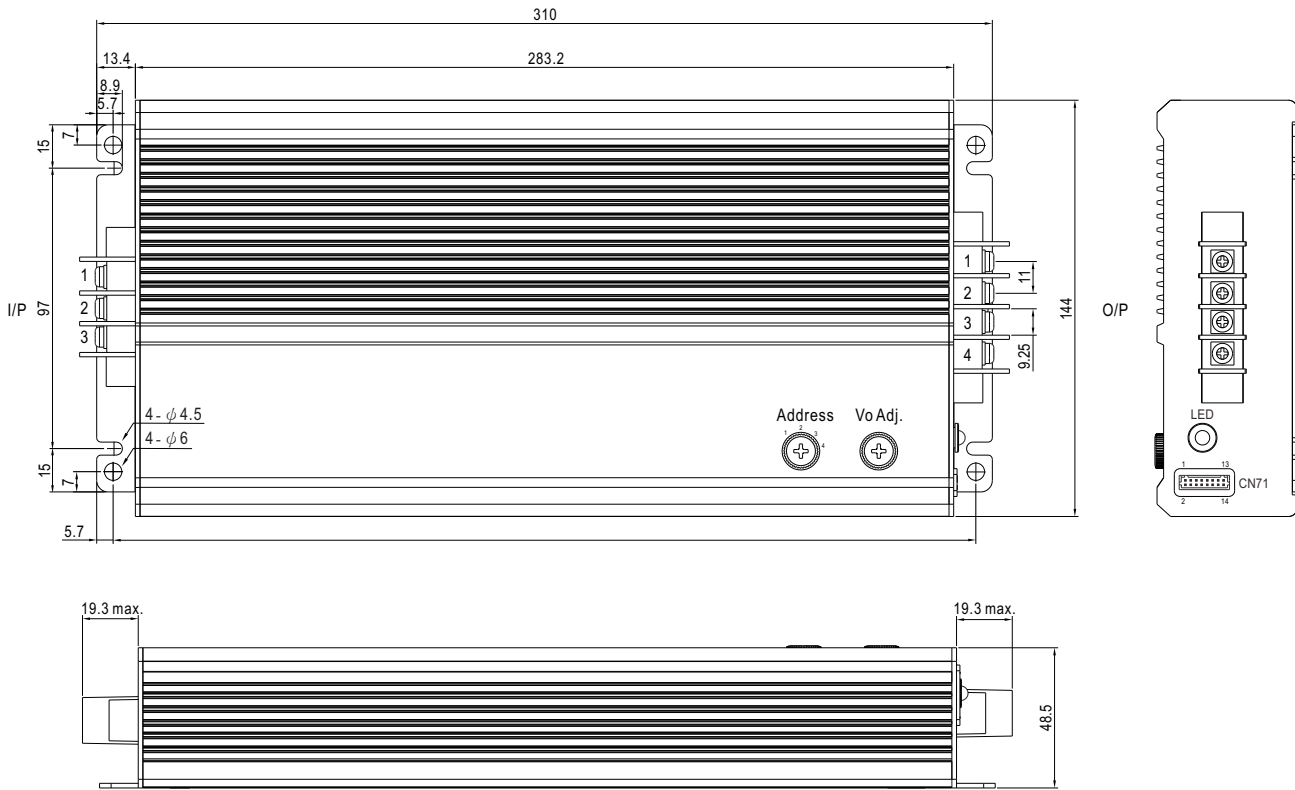

- ※ Output voltage current level can be adjusted through internal potentiometer.(Vo Adj.)
(Can access by removing the rubber stopper on the case.)
- ※ PMBus interface address selection.(Address)

AC Input Terminal Pin No. Assignment

Pin No.	Assignment
1	FG ⊕
2	AC/L
3	AC/N

DC Output Terminal Pin No. Assignment

Pin No.	Assignment
1,2	-V
3,4	+V

Figure 2-1

※ LED Status Indicators

Power supply mode

LED	Description
● Green	The unit functions normally
● Red (Flashing)	The LED will flash with red light when internal temperature reaches 95°C. Under this condition, the unit is still operating normally without entering OTP. (In the meantime, an alarm signal will be sent out through the PMBus/CANBus interface)
● Red	Abnormal status (Over temperature protection, overload protection)

Charger mode

LED	Description
● Green	Float(stage 3)
● Orange	Charging (stage 1 or stage 2)
● Red (Flashing)	The LED will flash with red light when internal temperature reaches 95°C. Under this condition, the unit is still operating normally without entering OTP. (In the meantime, an alarm signal will be sent out through the PMBus/CANBus interface)
● Red	Abnormal status (Over temperature protection, charge timeout)

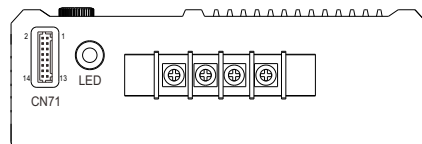
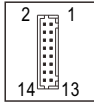

Figure 2-2 HEP-1000 output panel

※ Control Pin No. Assignment(CN71)



Pin No.	Function	Description
1	PV	Connection for output voltage programming.(Note1)
2	PC	Connection for constant current level programming.(Note.1)
3,4	GND (Signal)	Negative output voltage signal.
5	Remote ON-OFF	The unit can turn the output ON/OFF by dry contact between Remote ON/OFF and 12-AUX.(Note.2) Short (0.8 ~ 13.2V) : Power ON ; Open(0 ~ 0.5V) : Power OFF ; The maximum input voltage is 13.2V
6	DC-OK	Low (0 ~ 0.5V) : When $V_{out} \leq 77\% \pm 6\%$ at power mode. $V_{out} \leq 66\% \pm 6\%$ at charger mode. High (4.4 ~ 5.5V) : When $V_{out} \geq 80\% \pm 6\%$ at power mode. $V_{out} \geq 67\% \pm 6\%$ at charger mode. The maximum sourcing current is 10mA and only for output. (Note.2)
7,8	+12V-AUX	Auxiliary voltage output, 10.8~13.2V, referenced to GND-AUX (pin9 & 10). The maximum load current is 0.5A. This output is not controlled by "Remote ON-OFF".
9,10	GND-AUX	Auxiliary voltage output GND. The signal return is isolated from the output terminals (+V & -V).
11	SDA	For PMBus model: Serial Data used in the PMBus interface. (Note.2)
	CANH	For CANBus model: Data line used in CANBus interface. (Note.2)
12	SCL	For PMBus model: Serial Clock used in the PMBus interface. (Note.2)
	CANL	For CANBus model: Data line used in CANBus interface. (Note.2)

Note1: Non-isolated signal, referenced to [GND(signal)].

Note2: Isolated signal, referenced to GND-AUX.

HEP-1000 Temperature compensation

13	+S	Positive sensing for remote sense.
14	-S	Negative sensing for remote sense.

◎To enable temperature compensation function, connect the NTC sensor that comes with the supply to RTH+ and RTH-. Default setting is $-3mV/Cell/^{\circ}C$, compensation values also can be adjusted to $4mV/Cell/^{\circ}C$ or $-5mV/Cell/^{\circ}C$ through the SBP-001, the charge programmer.

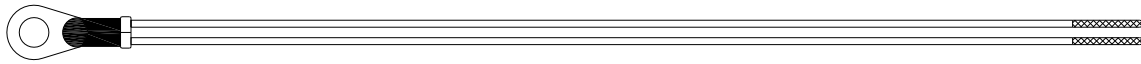

3.Functions

3.1 Input Voltage Range

- ◎The input voltage range is AC90~305V or DC250~431V.
- ◎To ensure proper operation, AC input should be within the pre-specified range. A wrong input will cause the supply unit operating improperly, losing PFC function or even damaging the unit in a worst case scenario.
- ◎The efficiency will be lower and the output current will be automatically limited to a predetermined safe value if the unit is applied with a lower input voltage. Please refer to 4.2 Derating for more information.

3.2 Inrush Current Limiting

- ◎Built-in inrush current limiting circuit .
- ◎If adding an external switch (a relay/ a circuit breaker) at the input side is required, choose switches that are able to withstand inrush current of the unit.
- ◎Since the inrush current limiting circuit mainly consists of a NTC thermistor and a relay, inrush current will be much higher than the specified value if the input thermistor is not allowed sufficient time to cool down. After turning off the supply, a 10 second cool down period is recommended before turning on again.

3.3 Output Power

- ◎Power supply mode

HEP-1000-24 : 1008W (24V / 42A)	HEP-1000-48 : 1008W (48V / 21A)
HEP-1000-100 : 1000W (100V / 10A)	
- ◎Charger mode

HEP-1000-24 : 1008W (28.8V / 35A)	HEP-1000-48 : 1008W (57.6V / 17.5A)
HEP-1000-100 : 1002W (115.2V / 8.7A)	

3.4 Power Factor Correction (PFC)

- ◎Built-in active power factor correction (PFC) function, power factor (PF) will be 0.95 or better when the input voltage is in a range of 90 ~ 230Vac and operated at full load condition. PF will be less than 0.95 if the output is not at full load or the input voltage is higher than 230Vac.

3.5 Output Voltage/Current Adjustmen

3.5.1 Output voltage adjustment

Output voltage can be trimmed by adjusting SVR (which can be found on the top case). Please utilize an insulated cross-head screwdriver to make an adjustment.

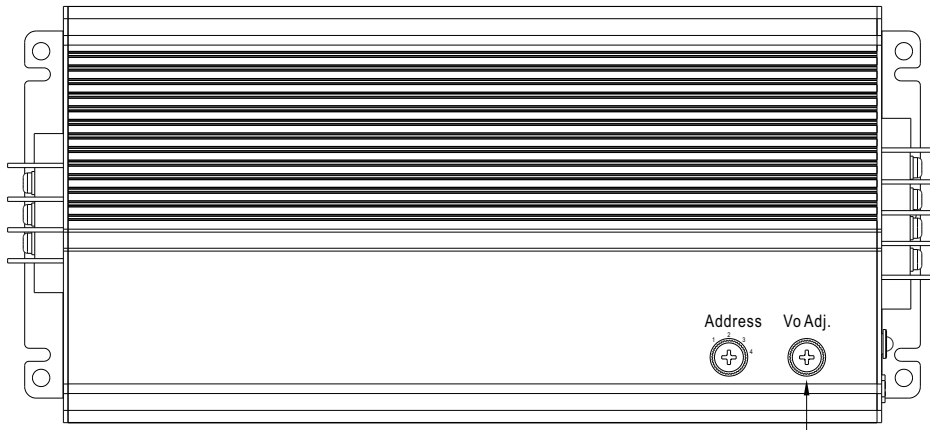

3.5.2 Output Voltage Adjustment by an External 0-5Vdc Source (Output Voltage Programming)

- (1) Connect output of the external DC source to PV (PIN 1) and GND (PIN 3 or PIN 4) on CN71, as shown in Figure 3-1.
- (2) Relationship between output voltage and external DC source is shown in Figure 3-2.
- (3) When increasing the output to a higher voltage level, please reduce the loading current accordingly. Output wattage of the unit should not exceed the rated value under any circumstance.

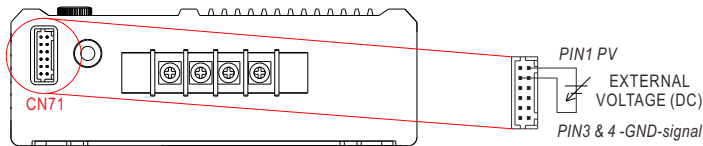

Figure 3-1 Connection of external DC voltage source

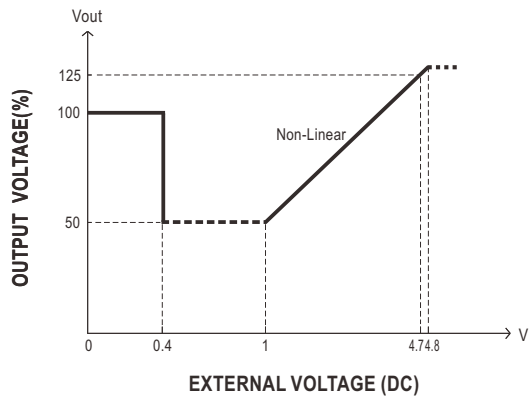
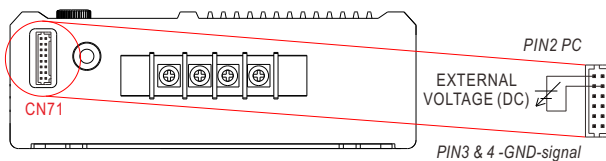

Figure 3-2

3.5.3 Output current adjustment (Output Current Programming)

※ Constant current level can be adjusted within a range of 20 -100% of the rated current via an external DC source, wiring is shown as below.



Relationship between output current and external DC source is shown as below.

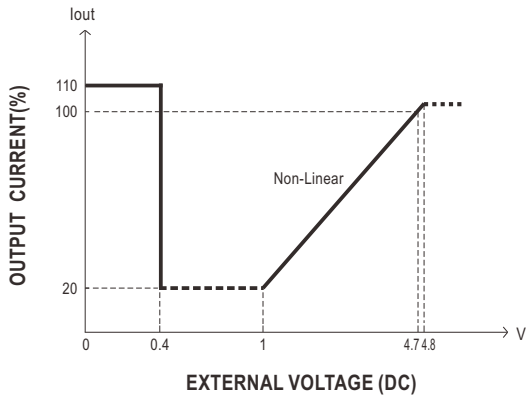

Note: The supply will trigger OLP to shut down itself if the output stays on constant current level condition for more than 5 seconds.

3.6 Short Circuit Protection & Over Current Protection

- ⊙ The protection activates when the output is short-circuited or the output current exceeds 110% ±5% of the rated output current. Re-power on to recover when the short-circuit/overload condition is removed.

3.7 Over Voltage Protection (OVP)

- ⊙ Built-in over voltage protection circuit.
- ⊙ OVP triggering points vary in different output models. Please refer to the specification sheet for detailed information.
- ⊙ Once OVP is triggered, leave the unit off for 10 seconds before recycling AC again.

3.8 Over Temperature Protection (OTP) and Alarm

- ⊙ Once the internal temperature exceeds a threshold value, the supply will shut down automatically. Please switch off the AC, remove all possible causes and then leave the unit cooling down to a normal working temperature (approximate 10 minutes ~ 1 hour) before re-power on again.
- ⊙ When the internal temperature reaches 95°C, trigger point of a thermal alarm, the LED will flash in red and there will be an alarm signal sent out through the PMBus/CANBus interface. Even so, the unit is still operating normally.

3.9 DC OK Signal

- ⊙ Built-in DC output voltage detection circuit.
- ⊙ When DC output voltage is within a normal range, there is "HIGH" (4.4 ~5.5V) signal sent out though DC-OK on CN71. (Referenced to GND-AUX).
- ⊙ When DC output voltage is out of a normal range, there is "LOW" (0 ~0.5V) signal sent out though DC-OK on CN71. (Referenced to GND-AUX).
- ⊙ Maximum output current 10mA.

3.10 Remote Control

- ⊙ Built-in remote ON/OFF control circuit. Refer to Figure 3-3.
- ⊙ Please be aware that "ON/OFF" and "+12V-AUX" on CN71 should be linked together to allow the unit to operate normally; if kept open, there will be no output voltage.
- ⊙ Maximum input voltage 13.2V.

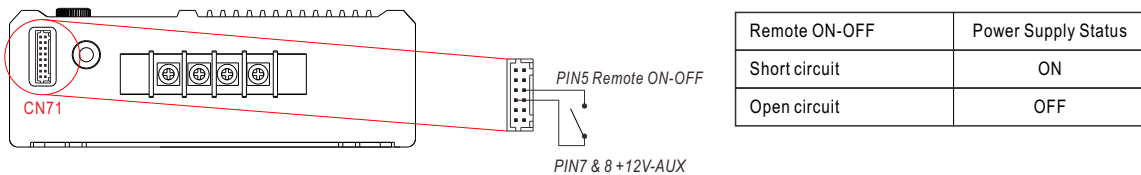

Figure 3-3 Connection of Remote Control

3.11 Auxiliary Output

- ⊙ Built-in 12V/0.5A auxiliary output.

3.12 Factory Resetting

Users can follow the steps below to restore factory settings for commands: 01h, 22h, 22h, 46h, BEh, B0~B7.

1. Set the rotary switch at position 1.
2. Turn on the AC without remote on, there should be no voltage at the output.
3. Within 15 seconds, rotate the switch from position 1 to position 4 and then back to position 1.
4. The green LED flashing 3 times means the process is successfully done.
5. Restart the supply to load factory settings.

4. Communication Protocol

There are two means to control the power supply, analog signals and digital communication. Analog is the default setting for the supply, signals including PV, PC and SVR can be used immediately once receiving the supply. The digital communication of PMBus or CANBus is initially uncontrollable but readable. To activate the digital communication, please set PM_CTRL/CAN_CTRL of SYSTEM_CONFIG(PM: BEh; CAN: 0xC200) at "1" and then reboot the supply. Once the digital communication dominates the supply, the analog signals become invalid.

- NOTE: 1. At default setting of analog, the following commands are invalid but can be written while other commands are effective: OPERATION(PM:01h; CAN: 0x0000), VOUT_TRIM/VOUT_SET(PM: 22h; CAN: 0x0020) and IOUT_OC_FAULT_LIMIT/OUT_SET(PM: 46h; CAN: 0x0030).
2. All written parameters of commands: PM: 01h, 22h and 46h; CAN: 0x0000, 0x0020 and 0x0030 are saved into EEPROM and take effect after the digital is activated.

4.1 Charging Curve

When it is opted for charging curve, CURVE_CONFIG (PM: B4h; CAN: 0x00B4): Low byte Bit 7 = 1, charging curve function is enabled with additional PMBus or CANBus commands. There are 4 built-in charging curves, "default" curve, one predefined curve for "gel battery", one pre-defined curve for "flooded battery" and one pre-defined curve for "AGM battery". Each curve can be selected by Command CURVE_CONFIG (PM: B4h; CAN: 0x00B4). In addition, users are able to customize their own charge curves, which will be stored to "default" after modification. Constant voltage level can be set by Command CURVE_CV (PM:B1h; CAN: 0x00B1); Float voltage level can be set by Command CURVE_FV (PM:B2h; CAN: 0x00B2); Charge current level of stage1 can be set by Command CURVE_CC (PM:B0h; CAN: 0x00B0); Taper current level from stage2 to stage3 can be set by Command CURVE_TC (PM:B3h; CAN: 0x00B3). Please refer to the command list of PMBus or CANBus for detailed information on commands and parameters.

- NOTE: 1. The updated charging parameters is saved into EEPROM. The updated charging curve takes effect after HEP-1000 is restarted, remoted on/off or operation on/off.
2. When charging curve is enabled, the following commands will be invalid while other commands are still effective: Command VOUT_TRIM(22h)/ VOUT_SET(0x0020) (regarding Output voltage programming function) and Command IOUT_OC_FAULT_LIMIT(46h)/ IOUT_SET(0x0030) (regarding Output current programming function).

☉ Default 3 stage charging curve

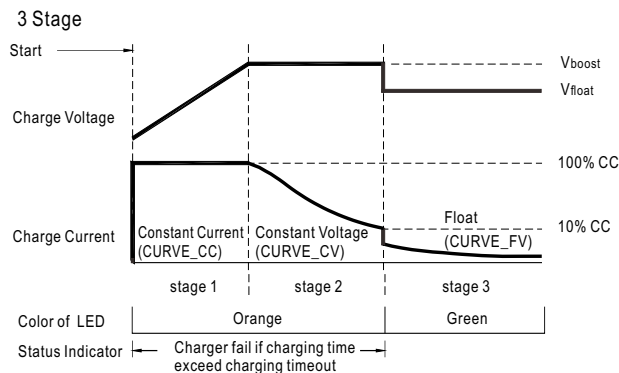

- ☉ Suitable for lead-acid batteries (flooded, Gel and AGM) and Li-ion batteries (lithium iron and lithium manganese).

Figure 4-1

☉ Embedded 3 stage charging curve

MODEL	Description	Vboost	Vfloat	CC (default)
24V	Default, programmable	28.8	27.6	35A
	Pre-defined, gel battery	28	27.2	
	Pre-defined, flooded battery	28.4	26.8	
	Pre-defined, AGM battery	29	27	
48V	Default, programmable	57.6	55.2	17.5A
	Pre-defined, gel battery	56	54.4	
	Pre-defined, flooded battery	56.8	53.6	
	Pre-defined, AGM battery	58	54	
100V	Default, programmable	115.2	110.4	8.7A
	Pre-defined, gel battery	112	108.8	
	Pre-defined, flooded battery	113.6	107.2	
	Pre-defined, AGM battery	116	108	

Table 4-1

Note:

When using this charger unit, please configured the system with recommended battery capacity by specification defined. Should battery capacity in use be much smaller so that user needs to set a low current for charging, under such condition it might cause higher current ripple.

4.2 PMBus Addressing and CAN ID setting

- ☉ Each HEP-1000 unit should have their unique and own device address to communicate over the bus.

*PMBus 7-bit addressing definition:

MSB						LSB
1	0	0	0	0	A1	A0

*CAN message ID definition :

Message ID	Description
0xC00XX	HEP-1000 to Controller Message ID
0xC01XX	Controller to HEP-1000 Message ID
0xC01FF	Controller broadcasts to HEP-1000

XX means the CAN ID of HEP-1000

A0-A1 allow users to designate an address for the HEP-1000 unit, these two bits are defined through a rotary witch on the top case. There are up to 4 different addresses are available to be assigned. Please refer to Table 4-2 for the detailed setup advice.

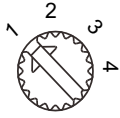

Device No.	Position of switch	Device address	
		A0	A1
0	1	0	0
1	2	1	0
2	3	0	1
3	4	1	1

Table 4-2

4.3 PMBus Command List

©The command list of the HEP-1000 is shown in Table 4-3. It is compliant with the standard protocol of PMBus Rev 1.1. For more detailed information, please refer to PMBus official website(<http://pmbus.org/specs.html>)

Table 4-3

Command Code	Command Name	Transaction Type	# of data Bytes	Description
01h	OPERATION	R/W Byte	1	Remote ON/OFF control
02h	ON_OFF_CONFIG	Read Byte	1	ON/OFF function configuration
19h	CAPABILITY	Read Byte	1	Capabilities of a PMBus device
20h	VOUT_MODE	R Byte	1	Define data format for output voltage (format: Linear 16, 24/48V:N= -9; 100V:N=-7)
21h	VOUT_COMMAND	R Word	2	Output voltage setting value (format: Linear 16, 24/48V:N= -9; 100V:N=-7)
22h	VOUT_TRIM	R/W Word	2	Output voltage trimmed value (format: Linear 16, 24/48V:N= -9; 100V:N=-7)
46h	IOUT_OC_FAULT_LIMIT	R/W Word	2	Output overcurrent setting value (format: Linear 11, 24/48V:N= -4; 100V:N=-6)
47h	IOUT_OC_FAULT_RESPONSE	R Byte	1	Define protection and response when an output overcurrent fault occurred
79h	STATUS_WORD	R Word	2	Summary status reporting
7Ah	STATUS_VOUT	R Byte	1	Output voltage status reporting
7Bh	STATUS_IOUT	R Byte	1	Output current status reporting
7Ch	STATUS_INPUT	R Byte	1	AC input voltage status reporting
7Dh	STATUS_TEMPERATURE	R Byte	1	Temperature status reporting
7Eh	STATUS_CML	R Byte	1	Communication, logic, Memory status reporting
80h	STATUS_MFR_SPECIFIC	R Byte	1	Manufacture specific status reporting
88h	READ_VIN	R Word	2	AC input voltage reading value (format: Linear 11, N=- 1)
8Bh	READ_VOUT	R Word	2	Output voltage reading value (format: Linear 16, 24/48V:N= -9; 100V:N=-7)
8Ch	READ_IOUT	R Word	2	Output current reading value (format: Linear 11, 24/48V:N= -4; 100V:N=-6)
8Dh	READ_TEMPERATURE_1	R Word	2	Temperature 1 reading value (format: Linear 11, N= -3)
98h	PMBUS_REVISION	R Byte	1	The compliant revision of the PMBus (default: 11h for Rev. 1.1)
99h	MFR_ID	Block Read	12	Manufacturer's name
9Ah	MFR_MODEL	Block Read	12	Manufacturer's model name
9Bh	MFR_REVISION	Block Read	24	Firmware revision
9Ch	MFR_LOCATION	Block R/W	3	Manufacturer's factory location

Valid when CURVE_CONFIG:CUVE = 1

Command Code	Command Name	Transaction Type	# of data Bytes	Description
9Dh	MFR_DATE	Block R/W	6	Manufacture date. (format: YYMMDD)
9Eh	MFR_SERIAL	Block R/W	12	Product serial number
B0h	CURVE_CC	R/W Word	2	Constant current setting value of charging curve (format: Linear 11, 24/48V:N= -4; 100V:N=-6)
B1h	CURVE_CV	R/W Word	2	Constant voltage setting value of charging curve (format: Linear 16, 24/48V:N= -9; 100V:N=-7)
B2h	CURVE_FV	R/W Word	2	Constant voltage setting value of charging curve (format: Linear 16, 24/48V:N= -9; 100V:N=-7)
B3h	CURVE_TC	R/W Word	2	Taper current setting value of charging curve (format: Linear 11, 24/48V:N= -4; 100V:N=-6)
B4h	CURVE_CONFIG	R/W Word	2	Configuration setting of charging curve
B5h	CURVE_CC_TIMEOUT	R/W Word	2	CC stage timeout setting value of charging curve (format: Linear, N= 0)
B6h	CURVE_CV_TIMEOUT	R/W Word	2	CV stage timeout setting value of charging curve (format: Linear, N= 0)
B7h	CURVE_FLOAT_TIMEOUT	R/W Word	2	Floating timeout setting value of charging curve (format: Linear, N= 0)
B8h	CHG_STATUS	READ Word	2	Charger's status reporting
BEh	SYSTEM_CONFIG	R/W Word	2	System setting
BFh	SYSTEM_STATUS	READ Word	2	System status

Note :

©Definition of Command B4h CURVE_CONFIG :

	Bit7	Bit6	Bit5	Bit4	Bit3	Bit2	Bit1	Bit0
High byte	-	-	-	-	-	FVTOE	CVTOE	CCTOE
Low byte	CUVE	STGS	-	-	TCS		CUVS	

Low byte

Bit 1-0 CUVS : Charge Curve Selection

00 = Customized Charge Curve (default)

01 = Gel Battery

10 = Flooded Battery

11 = AGM Battery

Bit 3-2 TCS: Temperature Compensation Setting

00 = disable

01 = -3 mV/°C/cell (default)

10 = -4 mV/°C/cell

11 = -5 mV/°C/cell

Bit 6 STGS: 2/3 Stage Charge Setting

0 = 3 stage charge (default, CURVE_VBST and CURVE_V FLOAT)

1 = 2 stage charge (only CURVE_VBST)

Bit 7 CUVE : Charge Curve Function Enable

0 = disabled , power supply mode(default)

1 = enabled , charger mode

High byte

Bit 0 CCTOE: Constant Current Stage Timeout Indication Enable

0 = disabled (default)

1 = enabled

Bit 1 CVTOE : Constant Voltage Stage Timeout Indication Enable

0 = disabled (default)

1 = enabled

Bit 2 FVTOE: Constant Voltage Stage Timeout Indication Enable

0 = disabled (default)

1 = enabled

©Definition of Command B8h CHG_STATUS :

	Bit7	Bit6	Bit5	Bit4	Bit3	Bit2	Bit1	Bit0
High byte	FVTOF	CVTOF	CCTOF	-	BTNC	NTCER	-	-
Low byte	-	-	-	-	FVM	CVM	CCM	FULLM

Low byte

Bit 0 FULLM : Fully Charged Mode Status

0 = NOT fully charged

1 = fully charged

Bit 1 CCM : Constant Current Mode Status

0 = the charger NOT in constant current mode

1 = the charger in constant current mode

Bit 2 CVM : Constant Voltage Mode Status

0 = the charger NOT in constant voltage mode

1 = the charger in constant voltage mode

Bit 3 FVM : Float Mode Status

0 = the charger NOT in float mode

1 = the charger in float mode

Bit 2 NTCER : Temperature Compensation Status

0 = NO short-circuit in the circuitry of temperature compensation

1 = the circuitry of temperature compensation has short-circuited

Bit 3 BTNC : Battery Detection

0 = battery detected

1 = No battery detected

Bit 5 CCTOF : Time Out Flag of Constant Current Mode

0 = NO time out in constant current mode

1 = constant current mode timed out

Bit 6 CVTOF : Time Out Flag of Constant Voltage Mode

0 = NO time out in constant voltage mode

1 = constant voltage mode timed out

Bit 7 FVTOF : Time Out Flag of Float Mode

0 = NO time out in float mode

1 = float mode timed out

Note:

NTCER : When Temperature Compensation Short occurs, the charger output will shut down and the LED indicator will turn red. The charger will automatically restart after the Temperature Compensation Short condition is removed.

BTNC : When there is no battery detected, the charger stops charging the battery and the LED indicator turns red. The charger needs to re-power on to re-start charging the battery.

CCTOF : When timeout arises in the Constant Current stage, the charger stops charging the battery and the LED indicator turns red. The charger needs to re-power on to re-start charging the battery.

CVTOF : When timeout arises in the Constant Voltage stage, the charger stops charging the battery and the LED indicator turns red. The charger needs to re-power on to re-start charging the battery.

FVTOF : When timeout arises in the Float stage, the charger stops charging the battery and the LED indicator turns green. This charging flow is finished; the charger needs to re-power on to start charging a different battery.

©Definition of Command BEh SYSTEM_CONFIG:

	Bit7	Bit6	Bit5	Bit4	Bit3	Bit2	Bit1	Bit0
High byte	-	-	-	-	-	-	-	-
Low byte	-	-	-	-	-	OPERATION_INIT		PM_CTRL

Low byte

Bit 0 PM_CTRL: PMBus Control Selection

0 = Output voltage and current controlled by SVR/PV/PC (default)

1 = Output voltage, current and remote ON/OFF controlled by PMBus (VOUT_TRIM, IOULT_FAULT_LIMIT, OPERATION)

Bit 1: 2 OPERATION_INIT : OPERATION_INIT : Initial Operational Behavior

0b00 = power on with 0x00: OFF

0b01 = power on with 0x80: ON(default)

0b10 = power on with the last setting

0b11 = Not used

Note: Unsupported settings display with "0"

©Definition of Command BFh SYSTEM_STATUS:

	Bit7	Bit6	Bit5	Bit4	Bit3	Bit2	Bit1	Bit0
High byte	-	-	-	-	-	-	-	-
Low byte	-	EEPER	INITIAL_STATE	ADL_ON	-	-	DC_OK	-

Low byte

Bit 1: DC_OK : The DC output Status

0 = DC output too low

1 = DC output at a normal range

Bit 4 ADL_ON : Active dummy load Status

0 = Active dummy load NOT activate

1 = Active dummy load activate

Bit 5 INITIAL_STATE : Initial Stage Indication

0 = The unit NOT in an initial state

1 = The unit in an initial state

Note: Unsupported settings display with "0"

Bit 6 EEPER: EEPROM Access Error

0 = EEPROM accessing normally

1 = EEPROM access error

Note:

1.EEPER: When EEPROM Access Error occurs, the supply stops working and the LED indicator turns red. The supply needs to re-power on to recover after the error condition is removed.

2.Unsupported settings display with "0".

4.3.1 Notes on PMBus

1.Insert a at least 50msec delay between commands

2.Examples for Format Conversion :

(1)LINEAR16 format : VOUT_COMMAND · VOUT_TRIM · READ_VOUT · CURVE_CV · CURVE_FV ·

Actual voltage = communication reading $V \times 2^N$. There are two definitions in the VOUT_MODE command that refer to N requirements.

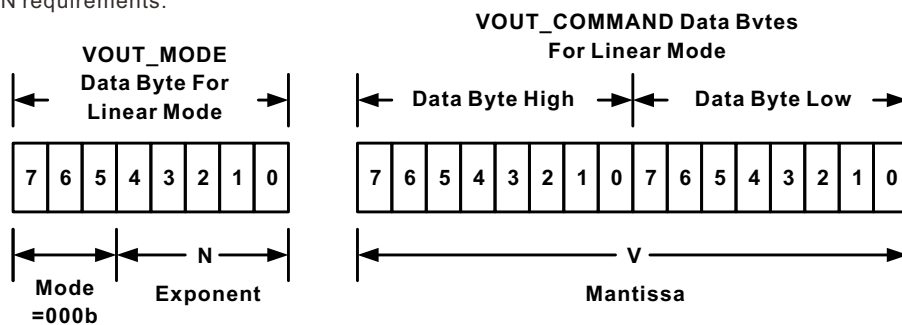

Linear Format Data Bytes

The Mode bits are set to 000b.

The Voltage, in volts, is calculated from the equation:

$$\text{Voltage} = V \cdot 2^N$$

Where:

Voltage is the parameter of interest in volts;

V is a 16 bit unsigned binary integer; and

N is a 5 bit two's complement binary integer.

EX: V_{o_real} (actual output voltage) = $V \times 2^N$, V is from READ_VOUT. N If VOUT_MODE = 0x17, meaning N is -9. READ_VOUT is 0x3000 12288, then $V_{o_real} = 12288 \times 2^{-9} = 24.0V$.

(2) LINEAR11 format : IOUT_OC_FAULT_LIMIT、READ_VIN、READ_IIN、READ_IOUT、READ_TEMPERATURE_1、READ_FAN_SPEED_1、READ_FAN_SPEED_2、CURVE_CC、CURVE_TC、CURVE_CC_TIMEOUT、CURVE_CV_TIMEOUT、CURVE_FV_TIMEOUT.

Actual value X = communication read value Y x 2^N. Among them, the definition of the description column for each aircraft type is referred to.

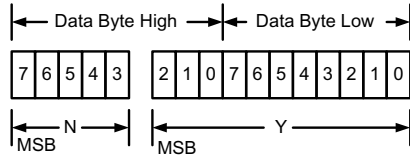

Linear Data Format Data Bytes Y, N and the "real world" value is:

The relation between

$$X = Y \cdot 2^N$$

Where, as described above:

X is the "real world" value;

Y is an 11 bit, two's complement integer; and

N is a 5 bit, two's complement integer.

Devices that use the Linear format must accept and be able to process any value of N.

EX: I_{o_real} (actual output current) = $Y \times 2^N$, Y is from READ_IOUT. N If READ_IOUT is 0xF188h, meaning N is -2 and Y is 0x0188. Y is 0x0188 → 392, then $I_{o_real} = 392 \times 2^{-2} = 98.0A$.

4.3.2 Communication Example - Practical Operation of Charger Mode

The following steps will describe how to set the HEP-1000-48 to charger mode and adjust its curve for a 2-stage charging process, with a constant current (CC) of 20A and a constant voltage (CV) of 56V.

1. Set the address of the HEP-1000 to "0".

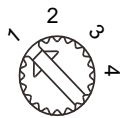

Device No.	Position of switch
0x00	1
0x01	2
0x02	3
0x03	4

2. Connect the SDA/SCL/GND to SDA(pin 11), SCL(pin 12) and GND-AUX(pin 9) of CN71.

Ⓢ Set speed: 100KHz

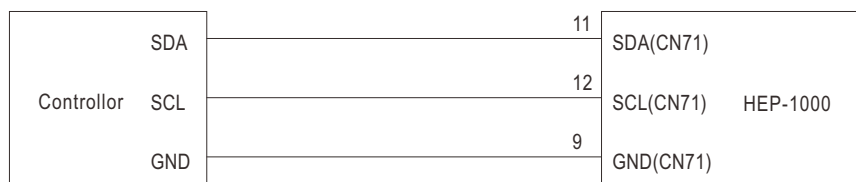

3.Communication function can be accessed immediately after HEP-1000 is connected to AC. Frist set it to 2-stage and charging mode.

Address(7 bit)	Operation	Command Code	Data
0x40	Write	0xB4	0xC0, 0x00

Command code: 0xB4(CURVE_CONFIG)

Data: 0xC0(Lo) + 0x00(Hi). Please refer to definition of CURVE_CONFIG for detailed information.

4.Set the constant current point to 20A.

Address(7 bit)	Operation	Command Code	Data
0x40	Write	0xB0	0xF0, 0x50

Command code: 0x22(CURVE_CC)

Data: 20A → 0xF0(Lo) + 0x50(Hi)

NOTE: VOUT_TRIM is LINEAR11 format

5.Set the constant voltage point to 56V.

Address(7 bit)	Operation	Command Code	Data
0x40	Write	0xB1	0x00, 0x70

Command code: 0x22(CURVE_CV)

Data: 56V → 0x00(Lo) + 0x70(Hi)

NOTE: VOUT_TRIM is LINEAR16 format

6.Before connecting to the batteries, it is recommended to review all of the settings and parameters using the appropriate commands. In the event that they do not meet your requirements, you may rewrite them as needed.

EX: Read CURVE_CV to check whether CV level or Vboost was set to a proper level.

Read CURVE_CV

Address(7 bit)	Operation	Command Code
0x40	Read	0xB1

The unit returns data below

Address(7 bit)	Data
0x40	0x00, 0x70

Data: 0x00(Lo) + 0x70(Hi) → 0x7000 → $28672 \times 2^{-9} = 56V$ °

6.Finally, check whether Remote ON-OFF and +12V-AUX pins of the CN71 connector are short-circuited if there is no output voltage.

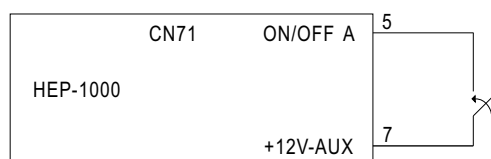

4.3.3 PMBus Data Range and Tolerance

◎Display parameters

PMBus command	Model	Range	Tolerance
READ_VIN	ALL	80 ~ 305V	±10V
READ_VOUT	24V	0 ~ 30V	±0.24V
	48V	0 ~ 60V	±0.48V
	100V	0 ~ 125V	±1V
READ_IOUT (Note. 1)	24V	0 ~ 50A	±1A
	48V	0 ~ 25A	±0.5A
	100V	0 ~ 12A	±0.25A
READ_TEMPERATURE_1	ALL	-40 ~ 110°C	±5°C

Table 4-4

◎Control parameter

PMBus command	Model	Range	Tolerance	Default
OPERATION	ALL	00h(OFF) / 80h(ON)	N/A	ON
VOUT_COMMAND	24V	24V	N/A	24V
	48V	48V	N/A	48V
	100V	100V	N/A	100V
VOUT_TRIM	24V	-12 ~ 6V	±0.24V	0V
	48V	-24 ~ 12V	±0.48V	0V
	100V	-50 ~ 25V	±1V	0V
CURVE_VBST	24V	18 ~ 30V	±0.24V	28.8V
	48V	36 ~ 60V	±0.48V	57.6V
	100V	72 ~ 120V	±1V	115.2V
CURVE_VFLOAT	24V	18V ~ VBST	±0.24V	27.6V
	48V	36V ~ VBST	±0.48V	55.2V
	100V	72V ~ VBST	±1V	110.4V
IOUT_OC_FAULT_LIMIT	24V	8.43 ~ 46.18A	±1A	46.18A
	48V	4.25 ~ 23.06A	±0.5A	23.06A
	100V	2 ~ 11A	±0.25A	11A
CURVE_ICHG	24V	7 ~ 35A	±1A	35A
	48V	3.5 ~ 17.5A	±0.5A	17.5A
	100V	1.75 ~ 8.7A	±0.25A	8.7A
CURVE_ITAPER	24V	1.75~10.5A	±1A	3.5A
	48V	0.87~5.25A	±0.5A	1.75A
	100V	0.45~2.6A	±0.25A	0.87A
CURVE_CONFIG	ALL	N/A	N/A	0004h
CURVE_CC_TIMEOUT	ALL	60~64800 minute	±5 minute	600 minute
CURVE_CV_TIMEOUT				
CURVE_FLOAT_TIMEOUT				
SYSTEM_CONFIG	ALL	N/A	N/A	02h

Table 4-5

Note:

1. READ_IOUT will display ZERO amp when output current is less than the values in the table below.

Model	Minimum readable current
24V	1.7A±1A
48V	0.85A±0.5A
100V	0.4A±0.25A

Table 4-6

2. When using PMBus to adjust output voltage, VOUT_COMMAND only can be used to display the rated voltage of the unit and cannot be written. It is VOUT_TRIM that provides voltage trimming function. Take HEP-1000-24 as an examples, to get a 12V output, please set value of VOUT_TRIM to -12V. Adjustable voltage range for each model is shown as below.

Model	Adjustable voltage range
24V	12 ~ 30V
48V	24 ~ 60V
100V	50 ~ 125V

Table 4-7

3. The value of CURBE_FV should be set less or equal to CURVE_CV, if CURVE_FV is greater than CURVE_CV, it will be saved as CURVE_FV = CURVECV in EPPROM.

4.4 CANBus Communication Interface

⊙Physical layer specification

This protocol follows CAN ISO-11898 with Baud rate of 250Kbps.

⊙Data Frame

This protocol uses Extended CAN 29-bit identifier frame format or CAN 2.0B.

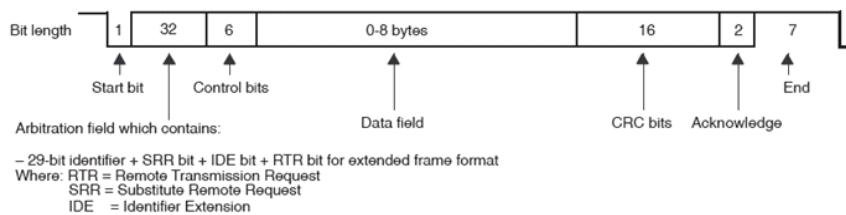

⊙Communication Timing

- Min. request period (Controller to HEP-1000): 50mSec °
- Max. response time (HEP-1000 to Controller): 12.5mSec °
- Min. packet margin time (Controller to HEP-1000): 12.5mSec °

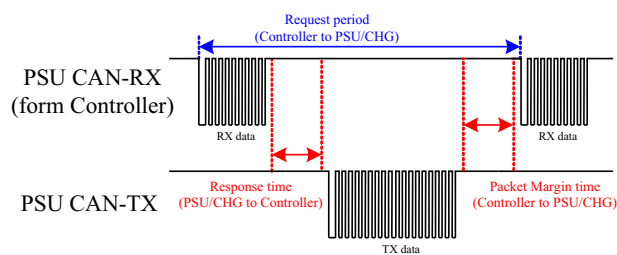

⊙Data Field Format

Controller to HEP-1000

Write:

Data filed bytes



Read:

Data filed bytes

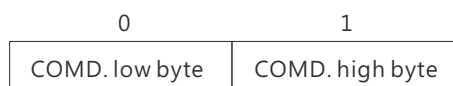

HEP-1000 to Controller

Response:

Data filed bytes

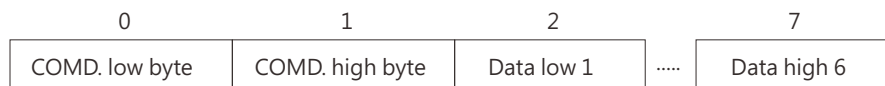

NOTE: HEP-1000 will not send data back when writing parameters, such as VOUT_SET

4.4.1 Message ID definition

Message ID	Description
0xC00XX	HEP-1000 to Controller Message ID
0xC01XX	Controller to HEP-1000 Message ID
0xC01FF	Controller broadcasts to HEP-1000

NOTE: XX means the address of HEP-1000 (which can be assigned by the address, range from rotary switch 0x00 ~ 0x03)

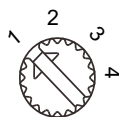

Device No.	Position of switch
0x00	1
0x01	2
0x02	3
0x03	4

4.5 CANBus Command list

Command Code	Command Name	Transaction Type	# of data Bytes	Description
0x0000	OPERATION	R/W	1	ON/OFF control ON: 01h OFF: 00h
0x0020	VOUT_SET	R/W	2	Output voltage set (format: value, F=0.01)
0x0030	IOUT_SET	R/W	2	Output current set (format: value, F=0.01)
0x0040	FAULT_STATUS	R	2	Abnormal status
0x0050	READ_VIN	R	2	Input voltage read value (format: value, F=0.1)
0x0060	READ_VOUT	R	2	Output voltage read value (format: value, F=0.01)
0x0061	READ_IOUT	R	2	Output current read value (format: value, F=0.01)
0x0062	READ_TEMPERATURE_1	R	2	Internal ambient temperature (format: value, F=0.1)
0x0080	MFR_ID_B0B5	R	6	Manufacture's name
0x0081	MFR_ID_B6B11	R	6	Manufacture's name
0x0082	MFR_MODEL_B0B5	R	6	Manufacture model name
0x0083	MFR_MODEL_B6B11	R	6	Manufacture model name
0x0084	MFR_REVISION_B0B5	R	6	Firmware version
0x0085	MFR_LOCATION_B0B2	R	3	Manufacture place
0x0086	MFR_DATE_B0B5	R	6	Manufacture date
0x0087	MFR_SERIAL_B0B5	R	6	Manufacture serial number
0x0088	MFR_SERIAL_B6B11	R	6	Manufacture serial number
0x00B0	CURVE_CC	R/W	2	Constant current setting of charge curve (format: value, F=0.01)

Valid when (CURVE_CONFIG:CUVE = 1)

Command Code	Command Name	Transaction Type	# of data Bytes	Description
0x00B1	CURVE_CV	R/W	2	Constant voltage setting of charge curve(format: value, F=0.01)
0x00B2	CURVE_FV	R/W	2	Floating voltage setting of charge curve(format: value, F=0.01)
0x00B3	CURVE_TC	R/W	2	Taper current setting of charge curve(format: value, F=0.01)
0x00B4	CURVE_CONFIG	R/W	2	Configuration setting of charge curve
0x00B5	CURVE_CC_TIMEOUT	R/W	2	CC charge timeout setting of charging curve
0x00B6	CURVE_CV_TIMEOUT	R/W	2	CV charge timeout setting of charging curve
0x00B7	CURVE_FV_TIMEOUT	R/W	2	FV charge timeout setting of charging curve
0x00B8	CHG_STATUS	R	2	Charging status reporting
0x00C0	SCALING_FACTOR	R	2	Scaling ratio
0x00C1	SYSTEM_STATUS	R	2	System status
0x00C2	SYSTEM_CONFIG	R/W	2	System configuration

Note:

The conversion of setting and reading values is defined as following:

Actual value = Communication reading value × Factor (F value). Among them, Factor needs to refer to the definition of SCALING_FACTOR in each model list.

EX: V_{o_real} (actual DC voltage) = READ_VOUT × Factor.

If the Factory of READ_VOUT of a certain mode is 0.01, the communication reading value is 0x0960 (hexadecimal)→2400(decimal), then $VDC_{real} = 2400 \times 0.01 = 24.0V$.

© Definition of Command FAULT_STATUS(0x0040) :

	Bit7	Bit6	Bit5	Bit4	Bit3	Bit2	Bit1	Bit0
Low byte	HI_TEMP	OP_OFF	AC_FAIL	SHORT	OLP	OVP	OTP	-

Bit 1 OTP : Over temperature protection
 0 = Internal temperature normal
 1 = Internal temperature abnormal

Bit 2 OVP : DC over voltage protection
 0 = DC voltage normal
 1 = DC over voltage protected

Bit 3 OLP : DC over current protection
 0 = DC current normal
 1 = DC over current protected

Bit 4 SHORT : Short circuit protection
 0 = Shorted circuit do not exist
 1 = Shorted circuit protected

Bit 5 AC_FAIL : AC abnormal flag
 0 = AC input range normal
 1 = AC input range abnormal

Bit 6 OP_OFF : DC status
 0 = DC output turned on
 1 = DC output turned off

Bit 7 HI_TEMP : Internal high temperature protection
 0 = Internal temperature normal
 1 = Internal temperature abnormal

Note: Unsupported settings displays with "0"

⊙MFR_ID_B0B5 (0x0080) is the first 6 codes of the manufacturer's name (ASCII); MFR_ID_B6B11 (0x0081) is the last 6 codes of the manufacturer's name (ASCII)

EX: Manufacturer's name is MEANWELL MFR_ID_B0B5 is MEANWE ; MFR_ID_B6B11 is LL

MFR_ID_B0B5					
Byte 0	Byte 1	Byte 2	Byte 3	Byte 4	Byte 5
0x4D	0x45	0x41	0x4E	0x57	0x45

MFR_ID_B6B11					
Byte 0	Byte 1	Byte 2	Byte 3	Byte 4	Byte 5
0x4C	0x4C	0x20	0x20	0x20	0x20

⊙MFR_MODEL_B0B5 (0x0082) is the first 6 codes of the manufacturer's model name (ASCII);

MFR_MODEL_B6B11 (0x0083) is the last 6 codes of the manufacturer's model name (ASCII)

EX: Model names is HEP-1000-24 → MFR_MODEL_B0B5 is HEP-24 ; MFR_MODEL_B6B11 is 00-24

MFR_MODEL_B0B5					
Byte 0	Byte 1	Byte 2	Byte 3	Byte 4	Byte 5
0x50	0x48	0x50	0x2D	0x33	0x35

MFR_ID_B6B11					
Byte 6	Byte 7	Byte 8	Byte 9	Byte 10	Byte 11
0x30	0x30	0x2D	0x32	0x34	0x20

⊙ MFR_REVISION_B0B5 (0x0084) is the firmware revision (hexadecimal).

A range of 0x00 (R00.0)~0xFE (R25.4) represents the firmware version of an MCU; 0xFF represents no MCU existed.

EX: The supply has two MCUs, the firmware version of the MCU number 1 is version R25.4 (0xFE), the MCU number 2 is version R10.5 (0x69)

Byte 0	Byte 1	Byte 2	Byte 3	Byte 4	Byte 5
0xFE	0x69	0xFF	0xFF	0xFF	0xFF

©MFR_DATE_B0B5 (0x0086) is manufacture date (ASCII)

EX: MFR_DATE_B0B5 is 180101, meaning 2018/01/01

Byte 0	Byte 1	Byte 2	Byte 3	Byte 4	Byte 5
0x31	0x38	0x30	0x31	0x30	0x31

©MFR_SERIAL_B0B5 (0x0087) and MFR_SERIAL_B6B11 (0x0088) are defined as manufacture date and manufacture serial number (ASCII)

EX: The first unit manufactured on 2018/01/01 → MFR_SERIAL_B0B5: 180101 ; MFR_SERIAL_B6B11: 000001

Byte 0	Byte 1	Byte 2	Byte 3	Byte 4	Byte 5
0x31	0x38	0x30	0x31	0x30	0x31

Byte 6	Byte 7	Byte 8	Byte 9	Byte 10	Byte 11
0x30	0x30	0x30	0x30	0x30	0x31

©CURVE_CONFIG(0x00B4) :

	Bit7	Bit6	Bit5	Bit4	Bit3	Bit2	Bit1	Bit0
High byte	-	-	-	-	-	FVTOE	CVTOE	CCTOE
Low byte	CUVE	-	-	-	TCS		CUVS	

Low byte

Bit 0 : 1 CUVS : Charge Curve Selection

00 = Customized charge Curve(default)

01 = Gel Battery

10 = Flooded Battery

11 = AGM Battery

Bit 2 : 3 TCS : Temperature Compensation Setting

00 = disable

01 = -3 mV/°C/cell (default)

10 = -4 mV/°C/cell

11 = -5 mV/°C/cell

Bit 6 STGS : 2/3 Stage Charge Setting

0 = 3 stage charge (default)

1 = 2 stage charge

Bit 7 CUVE : Charge Curve Function Enable

0 = disable(VI mode, default)

1 = enabled(Curve mode)

High byte:
 Bit 0 CCTOE : Constant Current Stage Timeout Indication Enable
 0 = disable (default)
 1 = enabled

Bit 1 CVTOE : Constant Voltage Stage Timeout Indication Enable
 0 = disable (default)
 1 = enabled

Bit 2 FTTOE : Float Voltage Stage Timeout Indication Enable
 0 = disable (default)
 1 = enabled

Note: Unsupported settings displays with "0"

©CHG_STATUS(0x00B8) :

	Bit7	Bit6	Bit5	Bit4	Bit3	Bit2	Bit1	Bit0
High byte	FVTOF	CVTOF	CCTOF	-	BTNC	NTCER	-	-
Low byte	-	-	-	-	FVM	CVM	CCM	FULLM

Low byte

Bit 0 FULLM :Fully Charged Mode Status
 0 = NOT fully charged
 1 = fully charged

Bit 1 CCM : Constant Current Mode Status
 0 = the charger NOT in constant current mode
 1 = the charger in constant current mode

Bit 2 CVM : Constant Voltage Mode Status
 0 = the charger NOT in constant voltage mode
 1 = the charger in constant voltage mode

Bit 3 FVM : Float Mode Status
 0 = the charger NOT in float mode
 1 = the charger in float mode

High byte:
 Bit 2 NTCER : Temperature Compensation Status
 0 = Temperature Compensation Status
 1 = the circuitry of temperature compensation has short-circuited

Bit 3 BTNC : Battery Detection
 0 = battery detected
 1 = No battery detected

Bit 5 CCTOF : Time Out Flag of Constant Current Mode
 0 = NO time out in constant current mode
 1 = constant current mode timed out

Bit 6 CVTOF : Time Out Flag of Constant Voltage Mode
 0 = NO time out in constant voltage mode
 1 = constant voltage mode timed out

Bit 7 FTTOF : Time Out Flag of Float Mode
 0 = NO time out in float mode
 1 = float mode timed out

Note: Unsupported settings displays with "0"

© SCALING_FACTOR(0x00C0) :

Bit7~Bit0								
byte4~5	Reserved							
	Bit7	Bit6	Bit5	Bit4	Bit3	Bit2	Bit1	Bit0
byte3	Reserved				IIN Factor			
	Bit7	Bit6	Bit5	Bit4	Bit3	Bit2	Bit1	Bit0
byte2	CURVE_TIMEOUT Factor				TEMPERATURE_1 Factor			
	Bit7	Bit6	Bit5	Bit4	Bit3	Bit2	Bit1	Bit0
byte1	FAN_SPEED Factor				VIN Factor			
	Bit7	Bit6	Bit5	Bit4	Bit3	Bit2	Bit1	Bit0
byte0	IOUT Factor				VOUT Factor			

byte0:

Bit 0:3 VOUT Factor : The factor of output voltage
 0x0=Output voltage relevant commands not supported
 0x4=0.001
 0x5=0.01
 0x6=0.1
 0x7=1.0
 0x8=10
 0x9=100

Bit 4:7 IOUT Factor : The Factor of DC current
 0x0=Output current relevant commands not supported
 0x4=0.001
 0x5=0.01
 0x6=0.1
 0x7=1.0
 0x8=10
 0x9=100

byte1:

Bit 0:3 VIN Factor : The Factor of AC input voltage
 0x0=AC input relevant commands not supported
 0x4=0.001
 0x5=0.01
 0x6=0.1
 0x7=1.0
 0x8=10
 0x9=100

Bit 4:7 FAN_SPEED Factor : The Factor of fan speed
 0x0=Fan speed relevant commands not supported
 0x4=0.001
 0x5=0.01
 0x6=0.1
 0x7=1.0
 0x8=10
 0x9=100

byte2:

Bit : 3 TEMPERATURE_1 Factor: 0 The Factor of internal ambient temperature
 0x0=internal ambient temperature relevant commands not supported
 0x4=0.001
 0x5=0.01
 0x6=0.1
 0x7=1.0
 0x8=10
 0x9=100

Bit 4:7 CURVE_TIMEOUT Factor : The Factor of CC/CV/Float timeout
 0x0=CURVE_TIMEOUT relevant commands not supported
 0x4=0.001
 0x5=0.01
 0x6=0.1
 0x7=1.0
 0x8=10
 0x9=100

byte3:
 Bit 0:3 IIN Factor : The Factor of AC input current
 0x0= AC input current relevant commands not supported
 0x4=0.001
 0x5=0.01
 0x6=0.1
 0x7=1.0
 0x8=10
 0x9=100

© SYSTEM_STATUS(0x00C1) :

	Bit7	Bit6	Bit5	Bit4	Bit3	Bit2	Bit1	Bit0
Low byte	-	EEPER	INITIAL-STATE	ADL_ON	-	-	DC_OK	-

Low byte:
 Bit 1 DC_OK : Secondary DD output voltage status
 0 = Secondary DD output voltage status TOO LOW
 1 = Secondary DD output voltage status NORMAL

Bit 4 ADL_ON : Active dummy load control status
 0 = Active dummy load off/function not supported
 1 = Active dummy load on

Bit 5 INITIAL_STATE : Device initialized status
 0 = NOT in initialization status
 1 = In initialization status

Bit 6 EEPER : EEPROM data access error
 0 = EEPROM data access normal
 1 = EEPROM data access error

Note: Unsupported settings displays with "0"

© SYSTEM_CONFIG(0x00C2):

	Bit7	Bit6	Bit5	Bit4	Bit3	Bit2	Bit1	Bit0
Low byte	-	-	-	-	-	OPERATION_INIT	CAN_CTRL	

Bit 0 CAN_CTRL : CANBus communication control status
 0 = The output voltage/current defined by control over SVR/PV/PC
 1 = The output voltage, current, ON/OFF control defined by control over CANBus (VOUT_SET, IOUT_SET, OPERATION)

Bit 1:2 OPERATION_INIT : Pre-set value of power on operation command
 0b00 = Power OFF, pre-set 0x00(OFF)
 0b01 = Power ON, pre-set 0x01(ON)
 0b10 = Pre-set is previous set value
 0b11 = not used, reserved

4.5.1 Sending command

The master adjusts output voltage of the unit with address "01" to 30V.

CAN ID	DLC (data length)	Command code	Parameters
0xC0101	0x4	0x2000	0x0006

Command code: 0x0020 (VOUT_SET) → 0x20(Lo) + 0x00(Hi)

Parameters: 30V → 3000 → 0x0600 → 0x00(Lo) + 0x06(Hi)

NOTE: Conversion factor for VOUT_SET is 0.01, so $\frac{30V}{F=0.01} = 3000$

4.5.2 Reading data or status

The master reads operation setting from the unit with address "00".

CAN ID	DLC (data length)	Command code
0xC0100	0x2	0x0000

The unit with address "00" returns data below

CAN ID	DLC (data length)	Command code	Parameters
0xC0000	0x3	0x0000	0x01

Parameters: 0x01 ON, meaning that the unit with address "00" is operating.

4.5.3 Communication Example - Practical Operation of Charger Mode

The following steps will describe how to set the HEP-1000-48 to charger mode and adjust its curve for a 2-stage charging

process, with a constant current (CC) of 20A and a constant voltage (CV) of 56V.

1. Set the address of the HEP-1000 to "0".

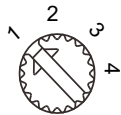

Device No.	Position of switch
0x00	1
0x01	2
0x02	3
0x03	4

2. Connect the CANH/CANL to CN71 CANH(pin 11), CANL(pin 12). Make the signals at the same level to increase communication reliability, that is: connect to the GND-AUX(9) of CN71.

Ⓞ Set baud rate: 250kbps, type: extended

Ⓞ Adding a 120Ω terminal resistor to both the controller and power supply ends can increase communication stability



3. Communication function can be accessed immediately after HEP-1000 is connected to AC. First set it to 2-stage and charging mode.

CAN ID	DLC(data length)	Command Code	Data
0xC0100	0x04	0xB400	0xC000

Command code: 0x00B4(CURVE_CONFIG)

Data: 0xC0(Lo) + 0x00(Hi) ◦ Please refer to definition of CURVE_CONFIG for detailed information.

4. Set the constant current point to 20A.

Address(7 bit)	Operation	Command Code	Data
0xC0100	0x04	0xB000	0xD007

Command code: 0x00B0(CURVE_CC)

Data: 20A → 2000 → 0x07D0 → 0xD0(Lo) + 0x07(Hi)

NOTE: Conversion factor for CURVE_CC is 0.01, so $\frac{20}{F=0.01} = 2000$

5. Set output voltage at 56V.

Address(7 bit)	Operation	Command Code	Data
0xC0100	0x04	0xB100	0xE015

Command code: 0x00B1(CURVE_CV)

Data: 56V → 5600 → 0x15E0 → 0xE0(Lo) + 0x15(Hi)

NOTE: Conversion factor for VOUT_SET is 0.01, so $\frac{56}{F=0.01} = 5600$

6. Before connecting to the batteries, it is recommended to review all of the settings and parameters using the appropriate commands. In the event that they do not meet your requirements, you may rewrite them as needed.

EX: Read CURVE_CV to check whether CV level or Vboost was set to a proper level.

Read CURVE_CV

Address(7 bit)	Operation	Command Code
0xC0100	0x04	0xB100

The unit returns data below

Address(7 bit)	Operation	Command Code	Data
0xC0100	0x04	0xB100	0xE015

Data: 0xE0(Lo) + 0x15(Hi) → 0x15E0 → 5600 = 56V ◦

6. Finally, check whether Remote ON-OFF and +12V-AUX pins of the CN71 connector are short-circuited if there is no output voltage.

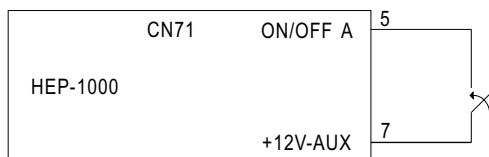

4.5.4 CANBus Value Range and Tolerance

(1)Display parameters

Command Name	Model	Display value range	Tolerance
READ_VIN	ALL	80~305V	±10V
READ_VOUT	24V	0~30V	±0.24V
	48V	0~60V	±0.48V
	100V	0~125V	±1V
READ_IOUT (Note. ii)	24V	0~50A	±1A
	48V	0~25A	±0.5A
	100V	0~12A	±0.25A
READ_TEMPERATURE_1	ALL	-40~110°C	±5°C

(2)Control parameters

Command Name	Model	Adjustable range	Tolerance	Default
OPERATION	ALL	00h(OFF)/01h(ON)	N/A	01h(ON)
VOUT_SET	24V	-12~6V	±0.24V	0V
	48V	-24~12V	±0.48V	0V
	100V	-50~25V	±1V	0V
CURVE_VBST	24V	18~30V	±0.24V	28.8V
	48V	36~60V	±0.48V	57.6V
	100V	72~120V	±1V	115.2V
IOUT_SET	24V	8.4~46.2A	±1A	46.2A
	48V	4.2~23.1A	±0.5A	23.1A
	100V	2~11A	±0.25A	11A
CURVE_ICHG	24V	7~35A	±1A	35A
	48V	3.5~17.5A	±0.5A	17.5A
	100V	1.75~8.7A	±0.25A	8.7A
CURVE_ITAPER	24V	1.75~10.5A	±1A	3.5A
	48V	0.85~5.25A	±0.5A	1.75A
	100V	0.45~2.6A	±0.25A	0.87A
CURVE_CONFIG	ALL	N/A	N/A	0004h
CURVE_CC_TIMEOUT	ALL	60~64800 minute	±5 minute	600 minute
CURVE_CV_TIMEOUT				
CURVE_FLOAT_TIMEOUT				
SYSTEM_CONFIG	ALL	N/A	N/A	02h

Note:

1. READ_IOUT will display ZERO amp when output current is less than the values in the table below.

Model	Minimum readable current
24V	1.7A±1A
48V	0.85A±0.5A
100V	0.4A±0.25A

Table 4-8

2. When using PMBus to adjust output voltage, VOUT_COMMAND only can be used to display the rated voltage of the unit and cannot be written. It is VOUT_TRIM that provides voltage trimming function. Take HEP-1000-24 as an examples, to get a 12V output, please set value of VOUT_TRIM to -12V. Adjustable voltage range for each model is shown as below.

Model	Adjustable voltage range
24V	12 ~ 30V
48V	24 ~ 60V
100V	50 ~ 125V

Table 4-9

3. The value of CURBE_FV should be set less or equal to CURVE_CV, if CURVE_FV is greater than CURVE_CV, it will be saved as CURVE_FV = CURVECV in EPPROM.

5. Notes on Operation

5.1 Wiring for battery

- Ⓞ Before battery connection, please make sure there is no reverse polarity. It is highly recommended using RED wire for (+) connection and BLACK wire for (-) connection.
- Ⓞ Select suitable wire gauge based on rated charging current, as table below.

AWG	CROSS SECTION(mm ²)	Max. Current(A) UL1015(600V 105°C)
10	5.265	35
12	3.309	22
14	2.081	12
16	1.309	8
18	0.823	6

Table 5-1 Suggested wire selection for input/output wirings

5.2 Derating

- Ⓞ When HEP-1000 is operating at a lower AC input voltage, it will de-rate its output current automatically to protect itself, shown as Figure 5-1.

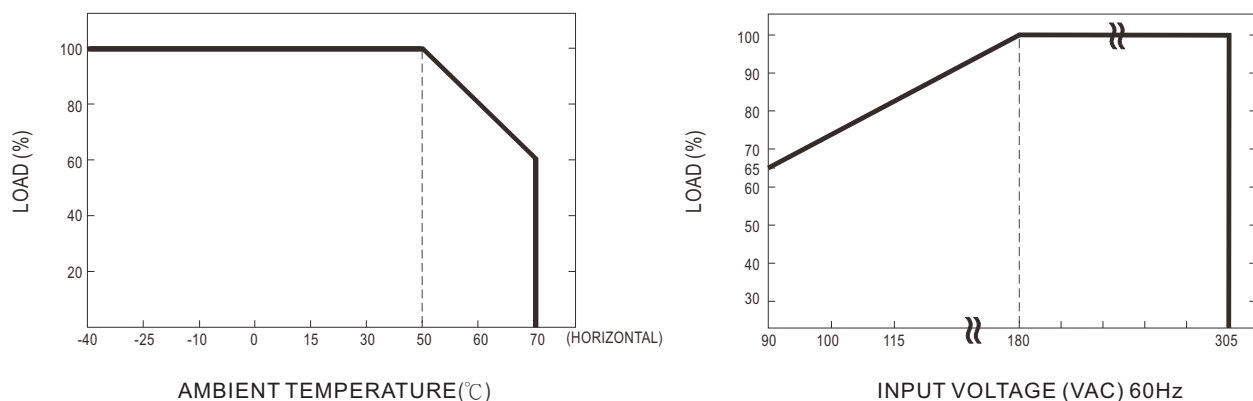

Figure 5-1 Output derating curves

5.3 Warranty

- Ⓞ A six year global warranty is provided under normal operation. Please do not change any component or modify the unit by yourself or MEANWELL may reserve the right not to provide the complete warranty service.

5.4 Suggestion of Battery Capacity

For Lead-acid

Model	Battery capacity
HEP-1000-24	120-350Ah
HEP-1000-48	60-175Ah
HEP-1000-100	30-85Ah

- Note: 1. Using battery capacity larger than the suggested value will not lead to damage of the battery. The main drawback is it may take longer to fully charge the battery.
2. If you are unsure about max allowable charging current of your battery, please refer to the battery's technical specification or consult its manufacturer.

5.5 Troubleshooting

If you are unable to clarify the problem you are facing, please contact MEAN WELL or any of our distributors for repair service.

Failure State	Possible Cause	Suggested Solutions
No output voltage	Output reverse polarity	Send back for repair
	Over temperature protection	Decrease the surrounding temperature
LED indicator does not turn Green after a long charging period	The charger in 2 stage charge	It is normal to show red LED in 2 stage charge when fully charged
	Output cables are too thin	Replace with suitable wire gauge
	Battery is over lifetime or damaged	Replace with a new battery

明緯企業股份有限公司

MEAN WELL ENTERPRISES CO., LTD.

248 新北市五股區五權三路28號

No.28, Wuquan 3rd Rd., Wugu Dist., New Taipei City 248, Taiwan

Tel: 886-2-2299-6100 Fax: 886-2-2299-6200

<http://www.meanwell.com> E-mail: info@meanwell.com

Your Reliable Power Partner